

# The Interactive Intelligence Difference

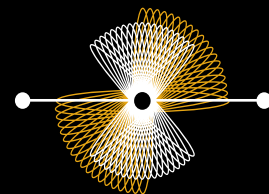

## Unified IP business communications from an Intelligent all-in-one platform

Centralise interaction and business processes with the Interaction Center Platform® technology. No complex integrations, no systems replication, and no need for costly multi-point legacy products — just a single powerful platform from one vendor. The way a business communications solution should be.



**INTERACTIVE INTELLIGENCE®**  
Deliberately Innovative

# The Unique Differentiators

## Traditional Legacy Hardware System

- Multiple systems
- Multiple vendors
- Higher implementation costs
- Higher maintenance costs
- Integration nightmares
- Administration headaches
- Overheating problems
- Rip and replace
- Limited SIP capability
- More points to secure
- Disconnected interaction channels
- Disconnected touch points
- Less productivity
- Unhappy customers
- And more!

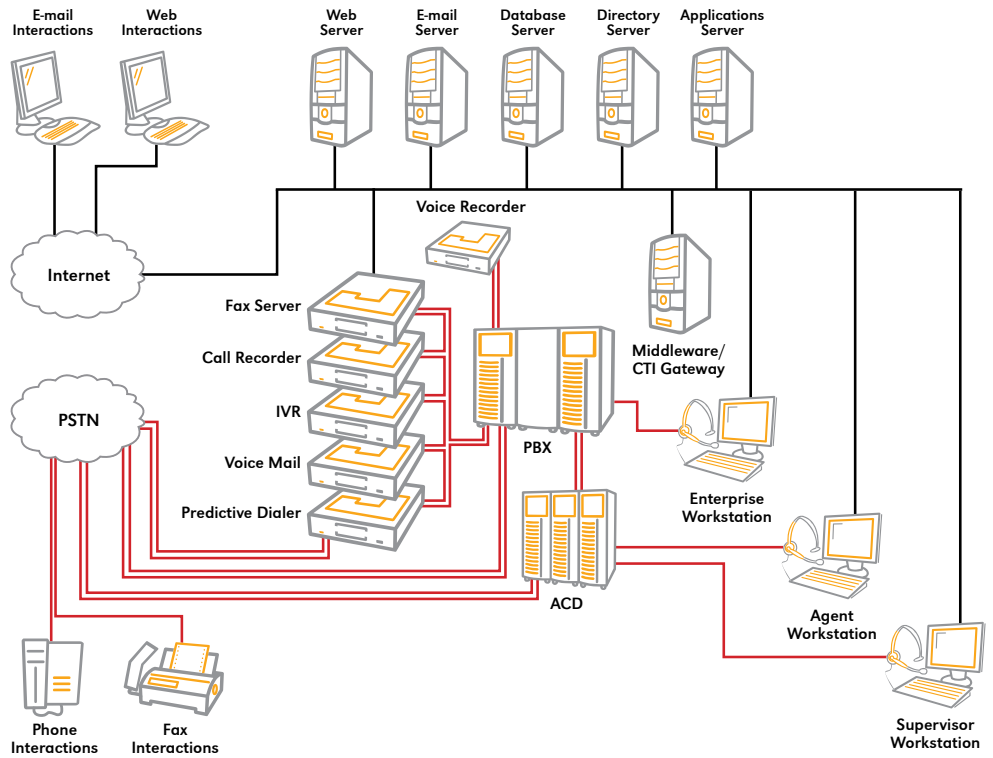

## Our Solution

- One system developed by one supplier
- No rip and replace
- All software
- Standards-based, open platform
- Multichannel on a single platform
- Easy integration to third-party applications
- Single point of administration
- Add users only once for all applications
- Licensing – add as you grow

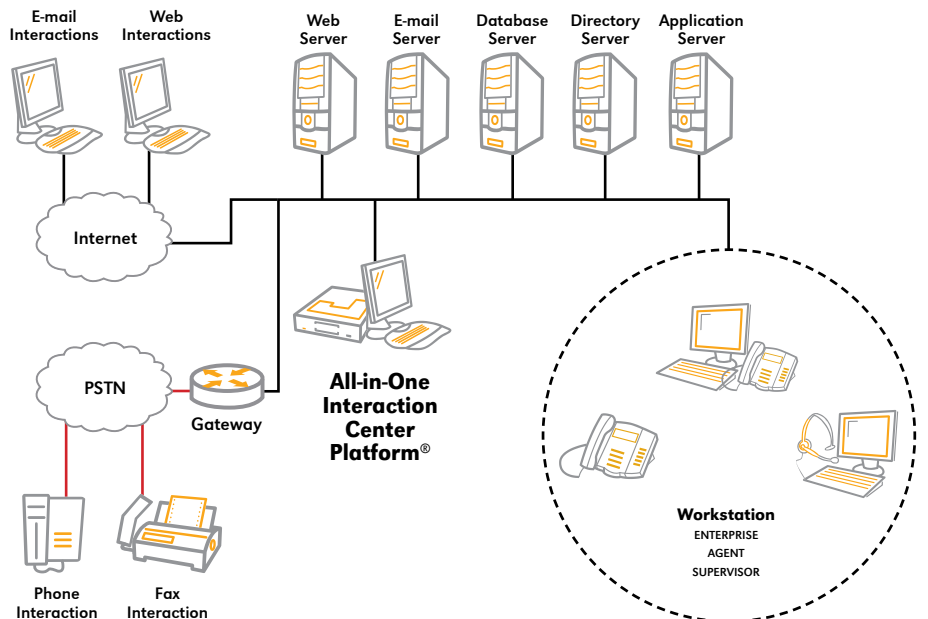

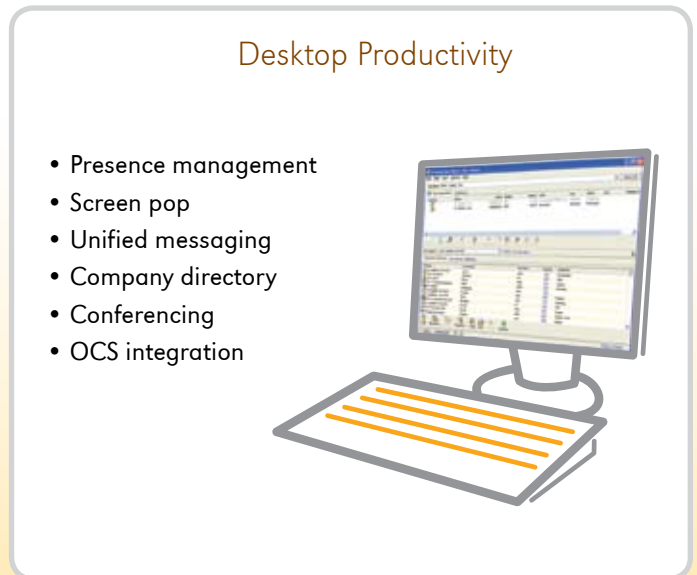
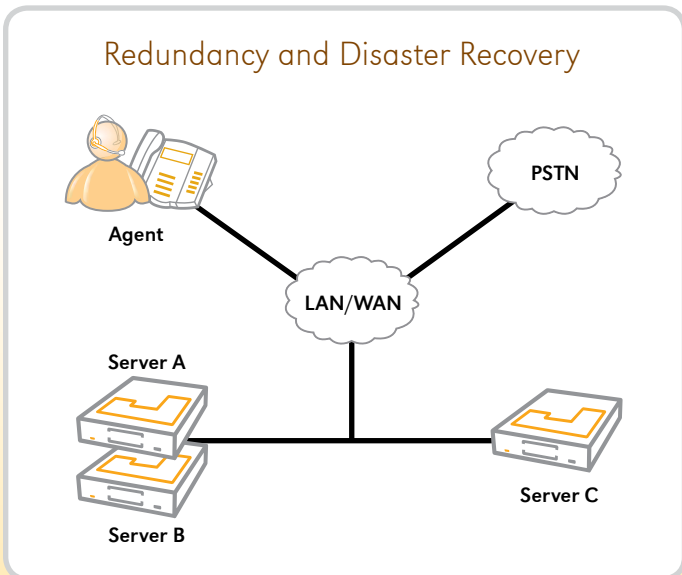
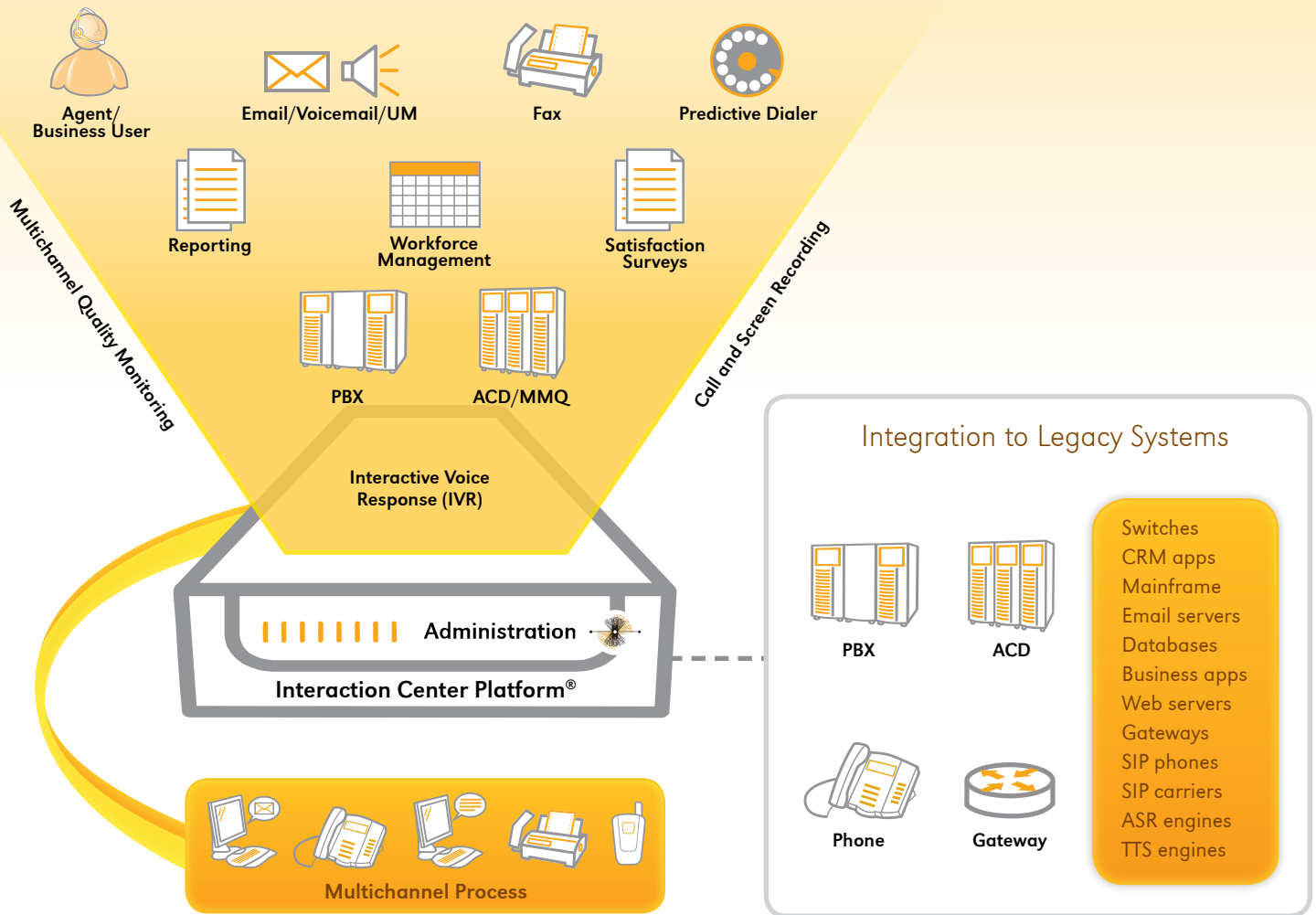

Blank lined area for notes or text.

Blank lined area for notes or text.

## The Interactive Intelligence Markets



Enterprise IP Telephony



The Contact Centre



Enterprise Messaging



**Parallax Technologies Corporation**

7640 Dixie Hwy., Clarkston MI 483436 Phone 800-929-2340

[www.parallaxtechnologies.com](http://www.parallaxtechnologies.com)